

UV SENSOR TYPE FD1-FD2

FLAME DETECTION DEVICES FOR FUEL OIL AND GAS BURNERS EMITTING BLUE LIGHT

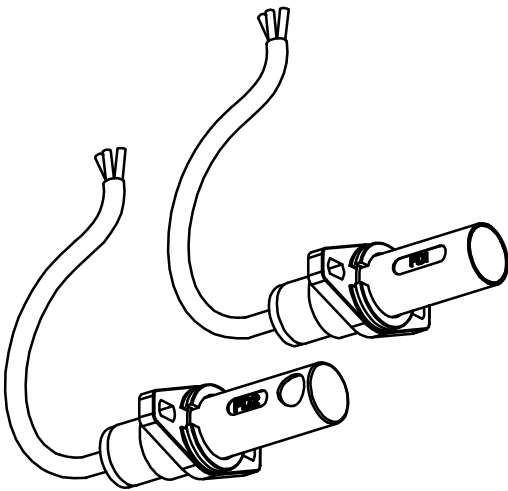

INTRODUCTION

The combustion process, depending on the type of fuel used, emits more or less light radiation belonging to the ultraviolet, visible or infrared spectrum.

Of course, gas oil combustion generates a very bright flame, which is easily detectable by means of sensors using common photocells; nevertheless, at the same time gas oil combustion generates a quantity of substances not completely burnt (unburnt substances), which pollute and also dirty the combustion chamber step by step.

By suitably adjusting the combustion, it is possible to solve this problem and improve the flame quality, making it similar to the flame produced by gas, natural gas or propane combustion (blue flame).

Since photocells are not sensitive to blue flame light, in most gas burners the presence of flame is detected by exploiting the ionization principle; to this purpose, you simply need an electrode (electrically isolated metal rod) suitably "immersed" in the flame. This principle is not easily applicable in oil burners, as the electrode immersed in the flame gets dirty quickly (consequently losing its efficiency) and modifies the turbulence in the combustion chamber, thus creating serious problems.

For all these reasons, it is necessary to detect the presence of flame by means of ultraviolet sensitive detectors.

DESCRIPTION

The FDx sensor uses a silicon preamplified active element, specifically designed for blue flame burner applications; the UV light peak detection of this sensor is around 310 nm.

Thanks to the incorporation of suitable electronic components, this device can be fitted to the BRAHMA control boxes of the EUROBOX, EUROFLAT, MINIFLAT, MICROFLAT and EUROGAS series (suitable for gas burner applications); moreover, this sensor is particularly well fitted for the control boxes type GR1, GR1/Z and GR2 of the EUROOIL series and for any control boxes of the OIL-SYSTEM series (suitable for oil burner applications).

In order to meet the widest range of market requirements, this device is available in the FD1 version (with front view) and in the FD2 version (with lateral view).

Please note that the FDx detector is sensitive to the ultraviolet component of visible light; therefore, its use is recommended in burners fitted with closed combustion chambers and in an application environment perfectly shielded from visible light.

FEATURES

- Supply voltage	220-240V/50-60Hz
- Power consumption	1VA
- Visible band	290-350nm
- Reception angle	8°
- Max. output current	500µA
- Operating temperature range	-20 to +60°C
- Max. humidity	95%

FD1 mechanical features

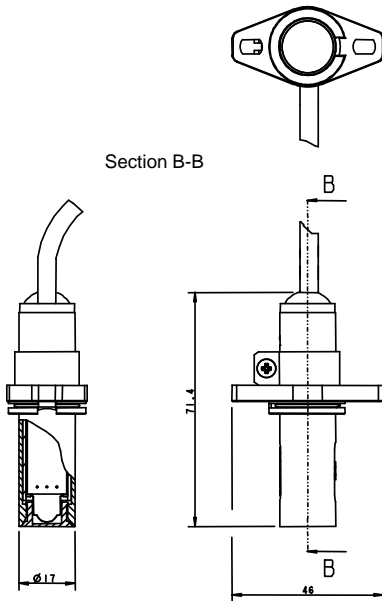

FD2 mechanical features

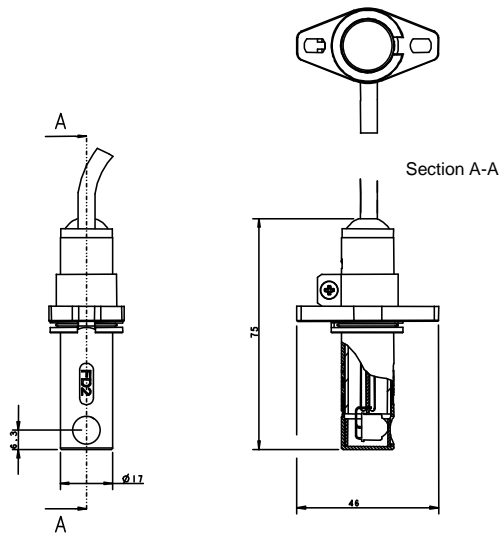

Drilling plane

For FD1 and FD2

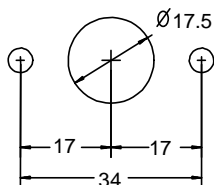

WARNINGS

For a correct and safe use of FDx sensors, please follow the directions below:

- Place the device so as for the flame light to strike the field of view (8°).
- Avoid placing unsuitable transparent materials between the sensor and the flame light to be detected; e.g., glass shows filter (shield) features towards the light ultraviolet component.
- Avoid installing the device close to heat sources, which may cause inner temperature increase and consequently damage the sensor.
- The device must be exclusively fitted to the control boxes mentioned in the paragraph "**Description**".
- Avoid wiring the FDx cable with ignition or high voltage cables.

WIRING DESCRIPTION

- Brown wire Live
- Blue wire Neutral
- White wire Output

APPLICATION EXAMPLE

The following diagram shows an application example with a gas oil burner using an EUROOIL safety device type GR1.

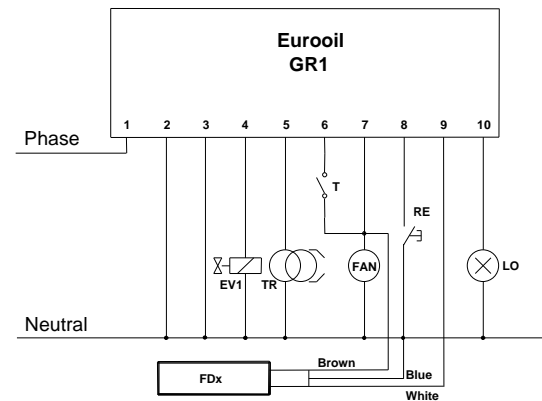

The following diagram instead shows an application example with a gas burner using an EUROGAS safety device type VM44G.

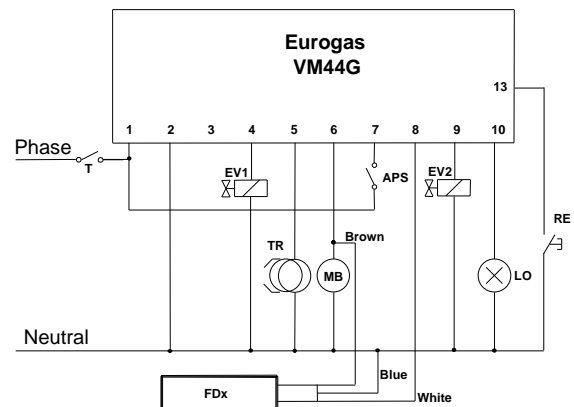

ATTENTION-> Company Brahma S.p.A. declines any responsibility for any damage resulting from the Customer's interfering with the device.

BRAHMA S.p.A.

Via del Pontiere, 31
37045 Legnago (VR)
Tel. +39 0442 635211 - Telefax +39 0442 25683
<http://www.brahma.it>
E-mail : brahma@brahma.it

07/07/02 Subject to amendments without notice