



ISO 9001



DETACTOGR®

UV Flame Safeguard

LFE50

Series 02

The LFE50... together with the QRA50M / QRA51M form a self-checking UV flame supervision system (DETACTOGR®) designed for use with continuously operating oil or gas burners or burners operating without interruption for more than 24 hours.

The LFE50... with the QRA50M / QRA51M and this Data Sheet are intended for use by OEMs which integrate the UV flame supervision system in their products.

Use

The DETACTOGR flame supervision system consists of the UV flame safeguard LFE50... and the flame detectors QRA50... / QRA51.... It is designed for UV supervision and can therefore be used in connection with oil burners, gas burners and gas / oil burners. Automatic startup and control of these burners must be ensured with a control unit LEC1... (refer to Data Sheet 7761). The system is also suited for the supervision of manually operated burners.

Prerequisite for the use of the DETACTOGR system is sufficiently high UV radiation at the flame detector's mounting location.

For combustion plant where heat generation must also be ensured in the event the flame supervision system fails, active redundancy circuitry can be accomplished by using 2 DETACTOGR systems.

General notes on application

A prerequisite for safe burner operation is an unambiguous flame signal that is initiated by the burner flame alone.

In the event of other effects due to failure that simulate a flame signal, the flame supervision equipment must stop any further burner operation.

In order to detect a simulated flame signal in due time, the burner control automatically performs a functional test of the flame supervision circuit after each controlled shutdown (or latest when the startup command for the burner is given). If the flame signal is simulated, the burner control will initiate lockout.

The protection achieved with this test is the more effective, the more frequently the burner is started up and the shorter the individual on times are.

To ensure a minimum test frequency in intermittent operation, the standards specify at least one controlled shutdown every 24-hour period.

Burners operating continuously must be supervised by a self-checking flame supervision system such as DETACTOGR.

Warning notes



To avoid injury to persons, damage to property or the environment, the following warning notes should be observed!

Do not open, interfere with or modify the unit!

- Before performing any wiring changes in the connection area of the LFE50..., completely isolate the flame safeguard from the mains supply (all-polar disconnection)
- Ensure protection against electric shock hazard by providing adequate protection for the flame safeguard's terminals
- Check wiring and all safety functions prior to commissioning and each time a fuse is changed
- Fall or shock can adversely affect the safety functions. Such units may not be put into operations, even if they do not exhibit any damage

Mounting notes

- Ensure that the relevant national safety regulations are complied with

Installation notes

- Installation work must be carried out by qualified staff

Electrical connection of the flame detector

It is important to achieve practically disturbance- and loss-free signal transmission:

- Never run the detector cable together with other cables
 - Line capacitance reduces the magnitude of the flame signal
 - Use a separate cable
- Observe the permissible lengths of the detector cables (refer to «Technical data»)
- Earth the burner in compliance with the relevant regulations; earthing the boiler alone does not suffice
- Always run the ignition cable separately while observing the greatest possible distances to the unit and to other cables

Commissioning notes

- Commissioning and maintenance work must be carried out by qualified staff

Disposal notes



The units contain electric and electronic components and may not be disposed of together with household garbage.
Local and currently valid legislation must be observed.

Mechanical design

Flame safeguard LFE50

The LFE50 is of plug-in design. It is suited for mounting in any position in control cabinets and on control panels. Direct mounting on the burner is also permitted.
The housing is made of impact-proof and heat-resistant plastic and accommodates the power section, the self-checking electronic flame signal amplifier with its flame relay, and a flame indication lamp.
The plug and socket arrangement is designed such that erroneous plugging in of another type of unit into the base is not possible. The spacious plug-in base with 4 auxiliary terminals and 4 earth looping terminals facilitates the electrical installation.

Flame detector QRA50M for mounting on a viewing tube (frontal incidence of light)

The die-cast alloy flame detector head is sealed with a quartz-glass lens. In addition to the plug-in UV cell, the head contains a rotating shutter which – for the purpose of continuous testing of the UV cell's striking and extinction voltage performance – interrupts the UV radiation at the rate of 3 times per second. The shutter is driven by a synchronous motor which is suited for continuous operation.



The flame detector is attached to the viewing tube by means of a flanged mounting coupling which has a 1 in. internal thread.
A 3/8 in. tapping on the side of the coupling enables a cooling air conduit to be connected, provided that dry, dust- and oil-free compressed air is available.

Flame detector QRA511M for mounting on the burner (lateral incidence of light)

The dust- and splashwater-proof housing of this flame detector has a flanged-on robust light metal tube with a radiation entry window for lateral viewing.
A cylindrical slotted shutter rotates in the tube which interrupts the incidence of UV radiation to the UV cell mounted directly behind the radiation entry window at the rate of about 3 times per second (continuous testing of the cell's striking and quenching performance).

The outer tube can be rotated through 180° by loosening 2 locking screws.
A special clamping flange is supplied with the flame detector to ensure its vibration- and turning-proof fixing to the burner.

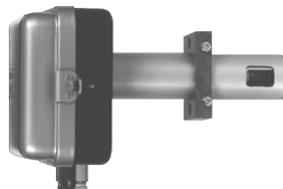

Type summary and ordering

Flame safeguard with terminal base

(terminal base 4 104 9023 0 is supplied together with the LFE50; no separate order required)

- AC 220...240 V

LFE50

- AC 100...110 V

LFE50 – AC 110 V

Flame safeguard without terminal base

LFE50A271



Flame detector for mounting on a viewing tube directed toward the combustion chamber, complete with flange (for all voltage versions)

QRA50M



Flame detector for mounting on the burner (lateral incidence of light) complete with clamping flange (for all voltage versions)

QRA51M



Spare UV cell

- For QRA50M

4 502 4268 0

- For QRA51M

4 502 4065 0

Technical data

Flame safeguard LFE50...	Mains voltage	AC 220 V -15 %...AC 240 V +10 % AC 100 V -15 %...AC 110 V +10 %
	Mains frequency	50...60 Hz \pm 6 %
	Unit fuse (built-in)	250 mA, slow, 5 x 20 mm
	Primary fuse (external)	max. 10 A, slow
	Power consumption	approx. 13 VA
	Perm. contact loading	max. 2 A
	Degree of protection	IP 40
	Mounting position	optional
	Weight	approx. 1.5 kg
	Operating voltage for	
	- UV cell	AC 250 V
	- Rotating shutter motor	AC 63 V
	Norms and standards	CE conformity
According to the directives of the European Union		
Electromagnetic compatibility EMC		89 / 336 EEC
Directive for gas-fired appliances		90 / 396 EEC
Low voltage directive		73 / 23 EEC
Flame detector	Degree of protection	
	- QRA50M	IP 54
	- QRA51M	IP 40
	Mounting position	optional
	Perm. pressure on the quartz-glass lens of the QRA50	max. 500 mbar
	Weight	approx. 0.75 kg
	Perm. detector cable length	
- When using a 5-core cable (for terminals 9, 10, 17, 18 and earth)	max. 30 m	
- When using a 2-core cable (for terminals 9 and 10 and a 3-core cable for terminals 17, 18 and earth)	max. 200 m	
Environmental conditions	Transport	IEC 60721-3-2
	Climatic conditions	class 2K2
	Mechanical conditions	class 2M2
	Temperature range	
	- LFE50...	-50...+60 °C
	- QRA50... / QRA51...	-55...+50 °C
	Humidity	< 95 % r.h.
	Operation	IEC 60721-3-3
	Climatic conditions	class 3K5
	Mechanical conditions	class 3M2
	Temperature range	
	- LFE50...	-20...+60 °C
	- QRA50... / QRA51...	-20...+50 °C
Humidity	< 95 % r.h.	
	Condensation, formation of ice and ingress of water are not permitted!	

Function

The flame is supervised by the UV cell which is permanently under voltage. When exposed to radiation from the 190...240 nm range of the flame spectrum, the UV cell strikes and gives rise to a flow of current to the input of the flame signal amplifier.

The flame signal is fed to the control circuit of the burner via the contacts of the flame relay at the amplifier output so that, in the event of loss of flame, the fuel valves will immediately be closed and, at the same time, all other necessary control commands will automatically be triggered (burner lockout, lockout alarm signal, etc.).

With a self-checking flame supervision system, it must be ensured that only the detector current emitted in the presence of a flame is amplified and used as the flame supervision signal.

An input current generated by a self-striking UV cell or some other defect may not be detected as a flame signal.

The flame safeguard must be capable of clearly differentiating between a true flame signal and an erroneous simulated signal.

For that purpose, the incident radiation at the UV cell is interrupted by a continuously rotating shutter at the rate of 3 times per second. The shutter is designed such that it allows «bright» and «dark» phases of practically equal length.

The input of the flame signal amplifier thus receives an input signal that is interrupted at regular intervals.

This ensures that the flame relay will be energized only if the following prerequisites are met:

- A flame is present
- The intensity of UV radiation at the viewing point of the detector must be of such a strength that the UV cell will reliably strike from the beginning to the end of the «bright» phase
- The shutter rotates at the defined speed so that the «bright» and «dark» phases occur at the uniform rate of 3 times per second
- The electric and electronic components of the flame signal amplifier function correctly

Prerequisites for troublefree burner operation

Checking the intensity of UV radiation at the flame detector's viewing point by measuring the detector current:

Required detector current at AC 220...240 V	min. 70 μ A
Detector current at AC 220...240 V	max. 140 μ A
Internal resistance of measuring instrument «M»	max. 5000 Ω
Capacitance of capacitor «C» (to make detector current reading easier)	min. 470 μ F / DC 25 V

Arrangement for measurement

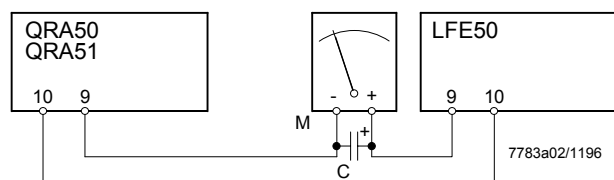

This check of UV radiation intensity at the detector and of the striking performance of the UV cell should be made not only during commissioning, but also each time the UV cell has been changed.

This check is also recommended in the case the original operating conditions of the burner have been changed, for example changes made to the burner head, introduction of combustion additives into the fuel (possible impact on the filter), or any other

changes carried out which may give rise to a reduction of incidence of radiation at the UV cell.

Locating the flame detector

The ignition spark is a source of intensive UV radiation.

In the case of oil or gas / oil burners with a long preignition time when firing on oil, the viewing tube of the detector should therefore be directed toward the flame in such a way that the ignition spark lies outside the angle of incidence of the UV radiation to the detector.

If this is not observed, the burner control will initiate lockout during the startup sequence due to extraneous light.

The discharge light of a UV cell can also be a source of disturbing UV radiation. This means that in the case of burner supervision with 2 flame detectors, it must be ensured that the detectors do not influence each other.

Powerful electron rays or X-rays can lead to faulty flame signals.

The same applies to UV proportions in the light of halogen or gas discharge lamps.

The QRA50M / QRA51M must be installed and adjusted in such a way that it only detects the supervised flame.



Protection of the detector head against excessive temperatures

The service life of a UV cell is reduced with increasing ambient temperatures.

In continuous operation, the operating temperature should not exceed 50 °C.

In the case of flame detectors mounted on a tube viewing into the combustion chamber, this temperature level will often be exceeded due to heat conduction. In this instance, the UV cell's ambient temperature must be lowered by means of cooling air that is blown through the viewing tube toward the combustion chamber (sketch A below).

Lateral entry of air at an angle of 90° to the viewing tube (sketch B below) is permitted only if the cooling air is dry and absolutely dust- and oil-free. Otherwise, the sealing disk of the detector head will become soiled, thereby reducing the incidence of radiation at the UV cell – or even block it completely.

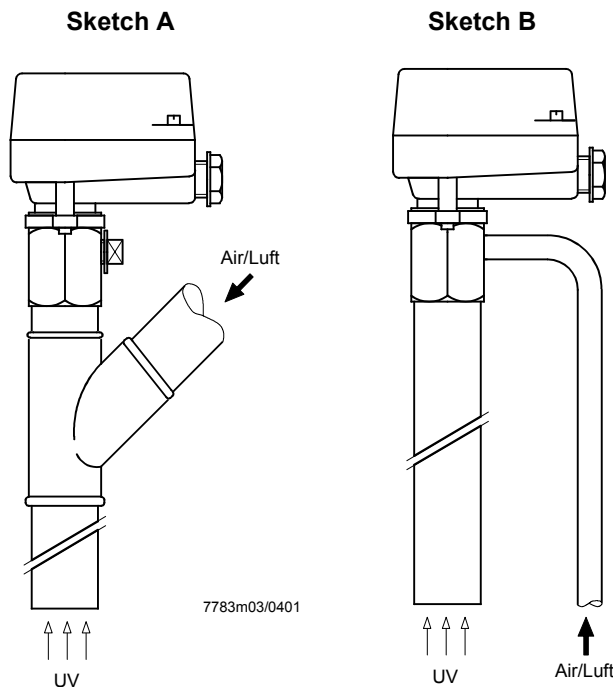

Connection diagram

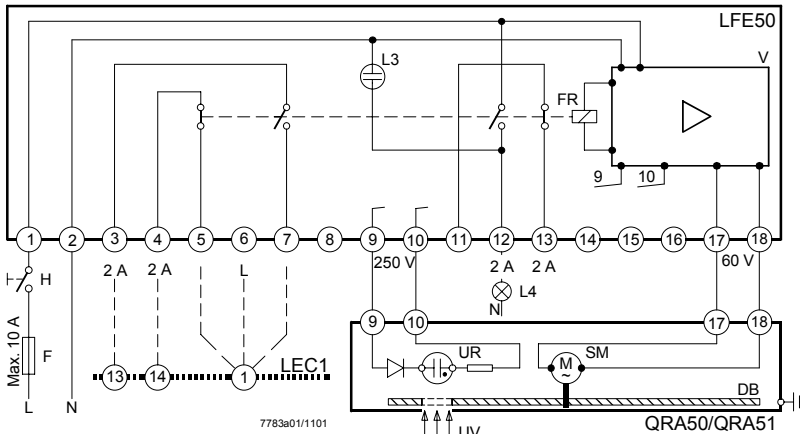

Legend

- DB Rotating shutter
- F Primary fuse (external)
- FR Flame relay
- H Main switch
- L3 Flame indication lamp (built-in)
- L4 Flame indication lamp (remote)
- LEC1... Control unit
- SM Synchronous motor with geartrain
- UR UV-sensitive tube (UV detector)
- UV UV radiation
- V Flame signal amplifier

Connection examples

Flame supervision of an expanding flame burner with DETACTOGR®

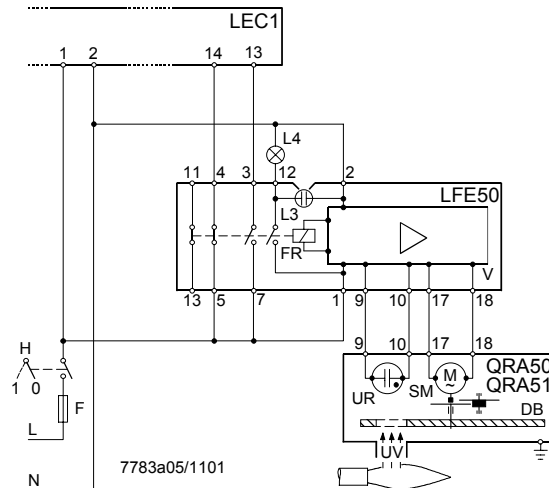

Legend

- DB Rotating shutter
- F Primary fuse (external)
- FR Flame relay
- H Main switch
- L3 Flame indication lamp (built-in)
- L4 Flame indication lamp (remote)
- LEC1... Control unit
- SM Synchronous motor with geartrain
- UR UV-sensitive tube (UV detector)
- UV UV radiation
- V Flame signal amplifier

Automatic operation

To control the burner, a control unit type LEC1... is required.

The burner is automatically switched on and off by the control thermostat or pressur-estat of the heat generation plant.

Semiautomatic operation

This operating mode differs from automatic operation only in that the burner is switched on manually (button «I»), provided signal lamp «L5» indicates that the control unit LEC1... is ready to start.

The burner is shut down either manually (button «0»), or automatically by a monitor in the control loop between terminals 8 and 9.

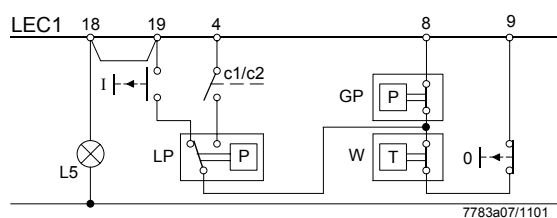

Legend

- GP Gas pressure monitor or similar
- L5 Signal «Ready to start»
- LEC1... Control unit
- LP Air pressure monitor
- W Temperature or pressure limiter

For connection examples showing the control of the burner, refer to Data Sheet 7761 (LEC1...).

Supervision of an expanding flame burner with 2 flame supervision systems DETACTOGRYR® in an active redundancy circuit

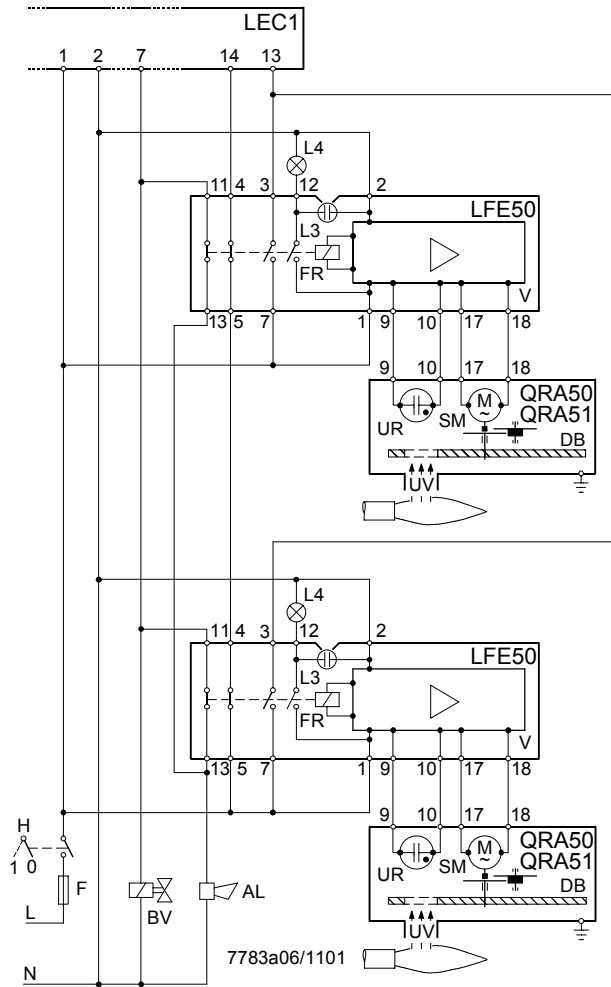

Legend

- AL Alarm
- BV... Fuel valve
- DB Rotating shutter
- F Primary fuse (external)
- FR Flame relay
- H Main switch
- L3 Flame indication lamp (built-in)
- L4 Flame indication lamp (remote)
- LEC1... Control unit
- SM Synchronous motor with geartrain
- UR UV-sensitive tube (UV detector)
- UV UV radiation
- V Flame signal amplifier

This circuit is used when heat generation by the burner must be maintained also in the event of a fault in the flame supervision circuit. In the case a flame safeguard or UV cell fails – indicated by a horn or similar – flame supervision will be ensured by the second supervision system, so that the fault can be corrected without shutting down the burner.

Flame supervision of the main flame (A) of an interrupted pilot burner with DETACTOGR®

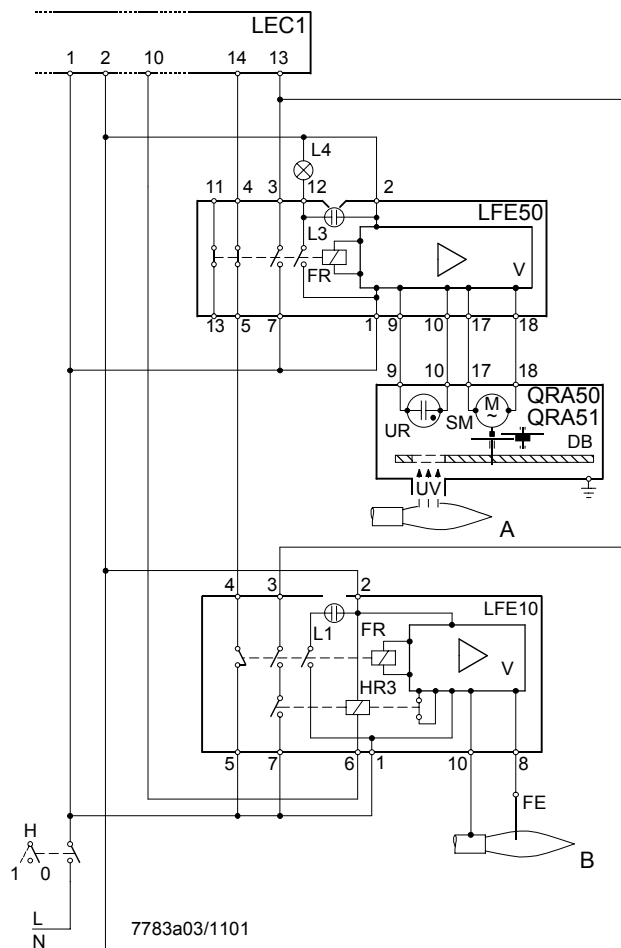

Legend

- A Flame safeguard for the main flame
- B Flame safeguard for the pilot flame
- DB Rotating shutter
- FE Ionization probe
- FR Flame relay
- H Main switch
- HR3 Auxiliary relay
- L1 Fault indication lamp (built-in)
- L3 Flame indication (built-in)
- L4 Flame indication (remote)
- LEC1... Control unit
- LFE10... Flame safeguard
- SM Synchronous motor with geartrain
- UR UV-sensitive tube (UV detector)
- UV UV radiation
- V Flame signal amplifier

Supervision of the pilot burner (B) with an ionization probe «FE» and a flame safeguard LFE10... until the end of the second safety time is reached.

The burner is controlled by a control unit LEC1... (refer to Data Sheet 7761 for the LEC1..., and Data Sheet 7781 for the LAE10... / LFE10...).

Flame supervision of a manually controlled burner with DETACTOGR®

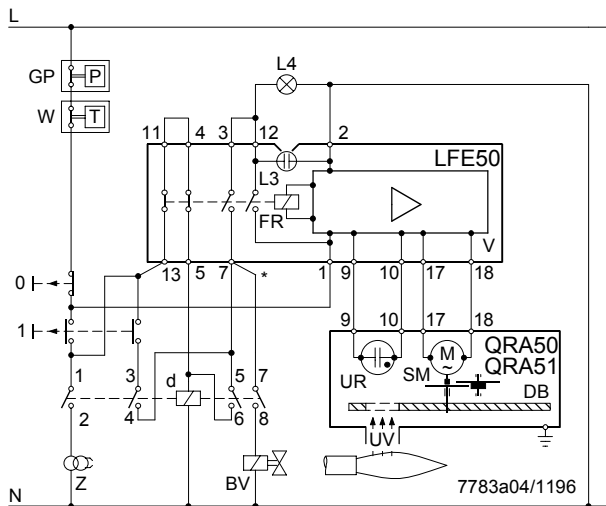

Legend

BV	Fuel valve
DB	Rotating shutter
FR	Flame relay
GP	Gas pressure monitor
L3	Flame indication (built-in)
L4	Flame indication (remote)
SM	Synchronous motor
UR	UV-sensitive tube (UV detector)
UV	UV radiation
V	Flame signal amplifier
W	Temperature or pressure limiter
Z	Ignition transformer

When button «l» is pressed, the ignition transformer will be switched on.

At the same time, relay «d» will be energized, thus releasing the supply of fuel.

The time during which button «l» may maintain its «start signal» should be limited by a time relay, if required – in the sense of a safety time.

When the burner ignites, flame relay «FR» will be energized so that relay «d» is held in the energized position via current path 3...7 of the flame safeguard.

When button «l» is released, the ignition transformer will be switched off, thus completing the startup sequence.

The burner is switched off manually by pressing button «0», or automatically via a monitor in the phase connection.

In the event of loss of flame or any other faults in the flame supervision circuit, the supply of fuel will immediately be shut off.

If such a fault occurs during a burner off period, neither ignition nor release of fuel will take place.



The drop-out delay time of relay «d» may not exceed 50 ms!

Dimensions

Dimensions in mm

Flame safeguard
LFE50...

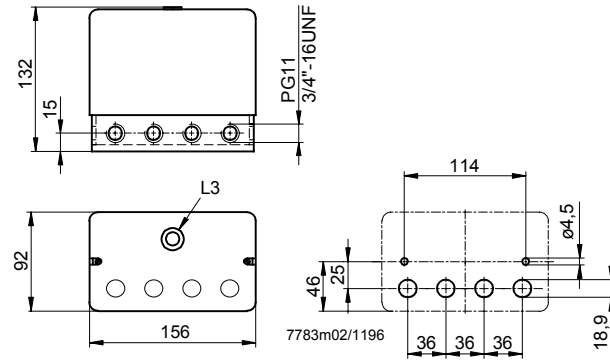

Flame detector
QRA50... / QRA51...

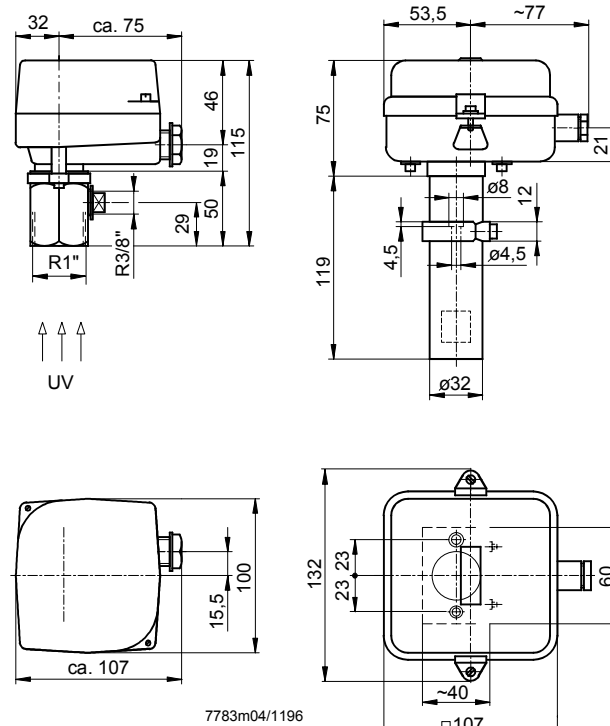

Flame detector QRA50...
(with mounting coupling)
for mounting on a viewing
tube directed toward the
combustion chamber

Flame detector QRA51...
for mounting on the burner