



ISO 9001
CE



Burner Controls

RMO88.53...
RMG88.62...
RMG/M88.62...

Microcontroller-based burner controls for the supervision of single- or multi-stage forced draft gas / oil burners in intermittent operation.
Oil throughput above 30 kg / h and a maximum capacity above 120 kW when firing on gas.

The RMO88.53... / RMG88.62... / RMG/M88.62... and this Data Sheet are intended for OEMs which integrate the burner controls in their products.

Use, features

| | |
|---------------|--|
| Use | The burner controls are designed for the startup and supervision of single- or multi-stage forced draft burners in intermittent operation. The RMO88.53... is for use with forced draft oil burners, the RMG88.62... / RMG/M88.62... for forced draft gas burners. When firing on oil, yellow-burning flames are supervised with photoresistive detectors QRB1B..., and blue-burning flames with blue-flame detectors QRC... When firing on gas, the flame is supervised with an ionization probe or flame detector QRA... (with ancillary unit AGQ2...A27). |
| Firing on oil | <ul style="list-style-type: none"> - Forced draft oil burners to EN 267 - Burner controls for use with atomization oil burners of monoblock design to EN 230 |
| Firing on gas | <ul style="list-style-type: none"> - Forced draft gas burners to EN 676 - Burner controls to EN 298 |

Application-specific features

When firing on oil

- Contact for preheating the oil
- Monitoring of time for preheating the oil
- Limitation of the number of repetitions

When firing on gas

- Monitoring of air pressure with functional check of the air pressure switch during startup and operation

General

- Undervoltage detection
- Electrical remote reset
- Accurate and reproducible program sequence owing to digital signal handling
- Controlled intermittent operation after 24 hours of continuous operation
- Multicolor display of status and error messages

Warning notes



To avoid injury to persons, damage to property or the environment, the following warning notes should be observed!

Do not open, interfere with or modify the unit!

- Before performing any wiring changes in the connection area, completely isolate the burner control from the mains supply (all-polar disconnection)
- Ensure protection against electric shock hazard by providing adequate protection for the burner control's terminals
- Check to ensure that wiring is in an orderly state and that the wires are firmly connected
- Press the lockout reset button of the burner control or the reset button extension AGK20.43 only manually (applying a force of no more than 10 N), without using any tools or pointed objects
- Fall or shock can adversely affect the safety functions. Such units may not be put into operation, even if they do not exhibit any damage

Engineering notes

- When used in connection with actuators, there is no position feedback signal from the actuator to the burner control
- The running times of the actuators must match the burner control's program. An additional safety check of the burner control together with the actuators is required

Mounting notes

- Ensure that the relevant national safety regulation are complied with

Installation notes

- Installation work must be carried out by qualified staff
- Observe the permissible lengths of the detector cables (refer to «Technical data»)
- Always run the high-voltage ignition cables separately while observing the greatest possible distances to the unit and to other cables
- Install switches, fuses, earthing, etc., in compliance with local regulations
- Ensure that the maximum permissible current ratings will not be exceeded (refer to «Technical data»)
- Do not feed external mains voltage to the control outputs of the unit. When testing the devices controlled by the burner control (fuel valves, etc.), the burner control must never be connected
- Phase and neutral conductors may not be interchanged

Electrical connection of ionization probe and flame detector

It is important to achieve practically disturbance- and loss-free signal transmission:

- The cable length must not exceed 1 m
- Never run the detector cable together with other cables
 - Line capacitance reduces the magnitude of the flame signal
 - Use a separate cable
- Insulation resistance
 - Must be a minimum of 50 M Ω between ionization probe and ground
 - Soiled detector holders reduce the insulation resistance, thus supporting creep age currents
- Earth the burner in compliance with the relevant regulations; earthing the boiler alone does not suffice

Only when firing on gas

- Observe the polarity
 - With supervision of the ionization current, the burner controls can detect wrong polarity of live and neutral conductors, in which case they initiate lockout at the end of «TSA»
- The ionization probe must be protected against electric shock hazard
- Locate the ionization probe such that
 - the ignition spark cannot arc over to the ionization probe (risk of electrical overloads)
 - the ignition spark cannot adversely affect supervision of the ionization current
- In networks with nonearthed neutral conductor and ionization current supervision, terminal 6 must be connected to burner ground

Commissioning notes

- Commissioning work must be carried out by qualified staff
- When commissioning the plant or when doing maintenance work, make the following safety checks:

| | Safety check | Anticipated response |
|----|--|--|
| a) | Burner startup with flame detector darkened or with open-circuit to the ionization probe | Lockout at the end of «TSA» |
| b) | Burner startup with flame detector exposed to extraneous light (only when firing on oil) | Lockout after no more than 25 seconds or immediate lockout during the prepurge time |
| c) | Burner operation with simulated flame failure; for that purpose, darken the flame detector during operation and maintain that status or interrupt the gas supply | Firing on oil: Repetition followed by lockout at the end of «TSA» Firing on gas: immediate lockout after the flame has extinguished |
| d) | Burner startup with response from air pressure switch (only when firing on gas) | Lockout at the end of the waiting time «tw» |
| e) | Burner operation with simulated loss of air pressure (only when firing on gas) | Immediate lockout |

Standards

Conformity to EEC directives

- Electromagnetic compatibility EMC (immunity) 89 / 336 EEC
- Directive for gas-fired appliances 90 / 396 EEC
- Low-voltage directive 73 / 23 EEC

Service notes

- Maintenance work must be carried out by qualified staff
- Each time a unit has been replaced, check to ensure that wiring is in an orderly state and that the wires are firmly connected. Make the safety checks as listed in «Commissioning notes»

Disposal notes



The unit contains electrical and electronic components and may not be disposed of together with household waste.
Local and currently valid legislation must be observed.

Mechanical design

The housing of the burner controls is made of impact-proof, heat-resistant and flame-retarding plastic.

The housing accommodates the

- microcontroller which controls the program sequence, and the relays for load control
- electronic flame signal amplifier (for the ionization probe when firing on gas, for the flame detector when firing on oil)
- lockout reset button with its integrated 3-color signal lamp for status and error messages and the socket for connecting the interface adapter OCI400
- terminals (maximum 15) for connecting the Riello base (part nos. 2061506 and 2221314)
- Central fixing screw for securing the housing to the Riello base (part nos. 2061506 and no. 2221314)

Display and diagnosis

- Multicolor display of status and error messages
- Transmission of status and error messages and detailed service information via additional interface adapter OCI400 and PC Windows software ACS400

Type summary

| | | |
|-----------------|---------------|----------------------|
| Type references | Riello | HVAC Products |
| Riello and | RMO88.53A1 | LMO88.530A1RL |
| HVAC Products | RMO88.53A2 | LMO88.530A2RL |
| | RMG88.62A1 | LMO88.620A1RL |
| | RMG88.62A2 | LMO88.620A2RL |
| | RMG/M88.62A2 | LMO88.621A2RL |

Firing on oil

| Type reference | Mains voltage | tw max. | TSA max. | t1 min. | t3 min. | t3n min. | t4 min. | t42 min. | Response in the event of loss of flame during operation |
|----------------|------------------------------|------------|-------------|------------|------------|-------------|------------|-------------|---|
| RMO88.53A2 | AC 220...240 V ¹⁾ | 2 s | 5 s | 23 s | 22 s | 7 s | 7 s | 7 s | Maximum 3 repetitions, followed by lockout |
| RMO88.53A1 | AC 100...120 V | 2 s | 5 s | 23 s | 22 s | 7 s | 7 s | 7 s | |

Firing on gas

| Type summary | Mains voltage | tw ²⁾ max. | TSA max. | t1 min. | t3n min. | t4 min. | t10 max. | t11 min. | t12 min. | Response in the event of loss of flame during operation |
|--------------|------------------------------|--------------------------|-------------|------------|-------------|------------|-------------|-------------|-------------|---|
| RMG88.62A2 | AC 220...240 V ¹⁾ | 2 s | 3 s | 25 s | 2 s | 10 s | 10 s | --- | 15 s | Lockout |
| RMG88.62A1 | AC 100...120 V | 2 s | 3 s | 25 s | 2 s | 10 s | 10 s | --- | 30 s | Lockout |
| RMG/M88.62A2 | AC 220...240 V ¹⁾ | 2 s | 3 s | 20 s | 2 s | 10 s | 10 s | 35 s | 30 s | Lockout |

| | | | | |
|--------|---------------|---|-----|--|
| Legend | TSA | Ignition safety time | t4 | Interval «BV1-BV2» |
| | tw | Waiting time | t42 | Interval «BV2-BV3» |
| | t1 | Prepurge time | t10 | Specified time for air pressure signal («LP» time) |
| | t3 | Preignition time | t11 | Programmed opening time for actuator «SA» |
| | t3n | Postignition time | t12 | Programmed closing time for actuator «SA» |
| | ¹⁾ | For applications outside the European Community, operation at mains voltage AC 200...240 V ±10 % is ensured | | |
| | ²⁾ | Max. 20 s, when «CPI» or «LP» are not in the idle position | | |

Ordering

Burner control including plug-in base

refer to «Type summary»

Photoresistive detector
(refer to Data Sheet 7714)

QRB1B...

Blue-flame detector
(refer to Data Sheet 7716)

QRC1...



Ancillary unit for UV supervision
- Cable length 500 mm
- Cable length 300 mm

AGQ2.1A27
AGQ2.2A27

Diagnostic tool
(refer to Data Sheet 7614)
- Hardware
- Software

OCI400
ACS400



Lockout reset button extension

AGK20.43

Technical data

| | | |
|---|--|--|
| General unit data | Mains voltage | |
| | - RMO88.53A2, RMG88.62A2 | AC 220...240 V +10 % / -15 % ¹⁾ 1) For applications outside the European Community, operation at mains voltage AC 200...240 V ±10 % is ensured |
| | - RMG/M88.62A2 | AC 220...240 V +10 % / -15 % |
| | - RMO88.53A1, RMG88.62A1 | AC 100...120 V +10 % / -15 % |
| | Mains frequency | 50...60 Hz ±6 % |
| | External primary fuse (Si) | |
| | - Only RMO88.53A1 | T6,3H250V (IEC 60 127-215) |
| | Built-in fuse (F) | T6,3H250V (IEC 60 127-215) |
| | - Not for RMO88.53A1 | |
| | Power consumption | 20 VA |
| | Mounting position | optional |
| | Weight | approx. 260 g |
| | Safety class | I |
| | Degree of protection | IP 20 (user must ensure min. IP 40 when built in) |
| | Tightening torque fixing screw M4 | max. 0.8 Nm |
| | Perm. cable length thermostat | max. 20 m at 100 pF / m |
| | Perm. cable length oil preheater | max. 20 m at 100 pF / m |
| | Perm cable length air pressure switch | max. 1 m at 100 pF / m |
| | Perm. cable length CPI | max. 1 m at 100 pF / m |
| | Perm. cable length gas pressure switch | max. 20 m at 100 pF / m |
| | Perm. cable length detector cable | max. 1 m |
| Perm. cable length remote reset | max. 20 m at 100 pF / m | |
| Undervoltage protection, switch-off voltage | | |
| - RMO88.53A2, RMG88.62A2 | approx. AC 165 V (AC 160...170 V) | |
| - RMO88.53A1, RMG88.62A1 | approx. AC 65 V (AC 60...70 V) | |
| - RMG/M88.62A2 | approx. AC 165 V (AC 160...175 V) | |

| Max. perm. amperage at $\cos\phi \geq 0.6$ | RMO88.53A2 | RMO88.53A1 | RMG88.62A2 RMG/M88.62A2 | RMG88.62A1 |
|--|-------------------|-------------------|----------------------------|-------------------|
| Terminal 1 | 5 A | 5 A | 5 A | --- |
| Terminal 2 | --- | --- | --- | 5 A |
| Terminal 3 | --- | --- | 0.5 A | 0.5 A |
| Terminal 4 | --- | --- | --- | 1 A |
| Terminal 5 | 1 A | 1 A | 1 A | --- |
| Terminal 7 | --- | --- | 5 A | --- |
| Terminal 10 | 1 A | 1 A | --- | 5 A |
| Terminal 11 | 5 A | 5 A | --- | --- |
| Terminal 12 | 2 A ²⁾ | 2 A ²⁾ | 1 A | 1 A |
| Terminal 13 | 1 A | 1 A | 2 A ²⁾ | 1 A |
| Terminal 14 | 1 A | 1 A | 1 A | 2 A ²⁾ |

²⁾ 3 A at a maximum of 150,000 switching cycles

Environmental conditions

| | |
|-----------------------|-------------------|
| Transport | DIN EN 60 721-3-2 |
| Climatic conditions | class 2K2 |
| Mechanical conditions | class 2M2 |
| Temperature range | -20...+70 °C |
| Humidity | < 95 % r.h. |
| Operation | DIN EN 60 721-3-3 |
| Climatic conditions | class 3K5 |
| Mechanical conditions | class 3M2 |
| Temperature range | -5...+60 °C |
| Humidity | < 95 % r.h. |



Condensation, formation of ice and ingress of water are not permitted!

Flame supervision with ionization probe (only when firing on gas)

| | At mains voltage UN = AC 100...120 V | At mains voltage UN = AC 220...240 V ¹⁾ |
|---|---|---|
| Detector voltage across ionization probe and ground (AC voltmeter, Ri ≥ 10 MΩ) | AC 50...120 V | AC 115...240 V |
| Switching threshold (limit values): Switching on (flame on, DC ammeter Ri ≤ 5 kΩ) Switching off (flame off, DC ammeter Ri ≤ 5 kΩ) | ≥ DC 1.5 μA ≤ DC 0.5 μA | |
| Detector current recommended for reliable operation | ≥ DC 6 μA | |
| Maximum short-circuit current between ionization probe and ground (AC Ri ≤ 5 kΩ) | AC 50...150 μA | AC 100...300 μA |

¹⁾ For applications outside the European Community, operation at mains voltage AC 200...240 V ±10 % is ensured

Flame supervision is accomplished by making use of the conductivity and rectifying effect of the flame.

The flame signal amplifier responds only to the DC component of the flame signal.
→ A short-circuit between ionization probe and ground causes the burner control to initiate lockout!

Measuring circuit

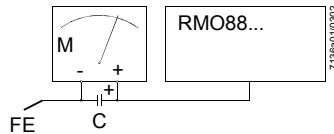

For detector currents, refer to «Technical data»

Legend

- C Electrolytic capacitor 100...470 μF; DC 10...25 V
- FE Ionization probe
- M Microammeter, Ri max. 5000 Ω

Flame supervision with AGQ2...A27 and flame detector QRA...

| | |
|--|------------------------|
| Mains voltage | AC 230 V +10 % / -15 % |
| Mains frequency | 50...60 Hz ±6 % |
| Perm. cable length from QRA... to AGQ2...A27 (lay separate cable) | max. 20 m |
| Perm. cable length from AGQ2...A27 to RMG88.62A2 | max. 2 m |
| Weight of AGQ2...A27 | approx. 140 g |
| Mounting position | optional |
| Degree of protection | IP 40 |
| Power consumption | 4.5 VA |

| | At mains voltage Un | |
|---|----------------------|----------------------|
| | AC 220 V | AC 240 V |
| Detector voltage at QRA... (with no load) | | |
| Until the end of «tw» and after controlled shutdown | DC 400 V | DC 400 V |
| After the end of «tw» | DC 300 V | DC 300 V |
| Detector voltage Load by DC measuring instrument Ri > 10 MΩ | | |
| Until the end of «tw» and after controlled shutdown | DC 380 V | DC 380 V |
| After the end of «tw» | DC 280 V | DC 280 V |
| DC current detector signals with flame detector QRA... | Min. required | Max. possible |
| Measurement at the flame detector | DC 200 μA | DC 500 μA |

Ancillary unit
AGQ2...A27

In connection with burner controls RMG88.62A2 / RMG/M88.62A2, use of the UV ancillary unit AGQ2...A27 is mandatory.

Operation with permanent line:

UV test with higher supply voltage across the UV cell on startup and after controlled shutdown.

Connection diagram

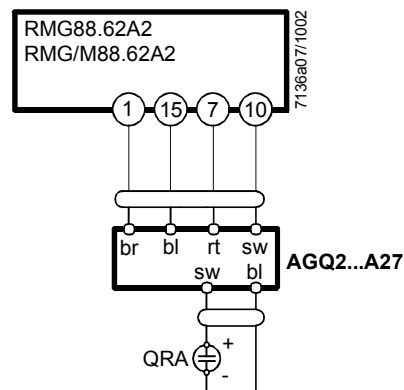

Measuring circuit

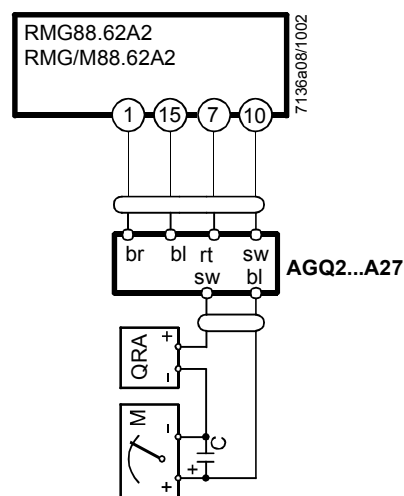

Measurement made at flame detector

Legend

- | | | | |
|--------|--|----|-------|
| C | Electrolytic capacitor 100...470 μ F; DC 10...25 V | bl | Blue |
| M | Microammeter Ri max. 5000 Ω | br | Brown |
| QRA... | Flame detector | rt | Red |
| | | sw | Black |

Flame supervision with
QRB1B... (only when
firing on oil)

At mains voltage UN = AC 100...120 V or UN = AC 220...240 V ¹⁾

| | Detector current | | | |
|----------|-------------------------------|------------------------------------|-----------------------------------|---|
| | Minimum required (with flame) | Recommended for reliable operation | Maximum permitted (without flame) | Maximum possible with flame (typically) |
| QRB1B... | DC 25 μ A | DC 35 μ A | DC 5.5 μ A | DC 100 μ A |

¹⁾ For applications outside the European Community, operation at mains voltage AC 200...240 V \pm 10 % is ensured

Measuring circuit for
detector resistance
measurement

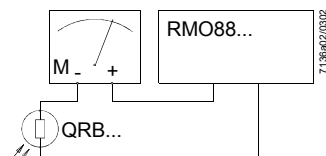

For detector currents, refer to «Technical data»

- Legend
- | | |
|----------|-------------------------------------|
| QRB1B... | Photoresistive detector |
| M | Microammeter, Ri max. 5000 Ω |

As an alternative to the detector resistance measurement, the diagnostic tool OCI400 / ACS400 can be used. In that case, use of a DC microammeter is not required.

Flame supervision with
 Riello photoresistive
 detector no. 2380226

| Photoresistive detector | Switching off (flame off) | Switching on (without flame) |
|-------------------------|---------------------------|------------------------------|
| No. 2380226 | 200 kΩ | 450 kΩ |

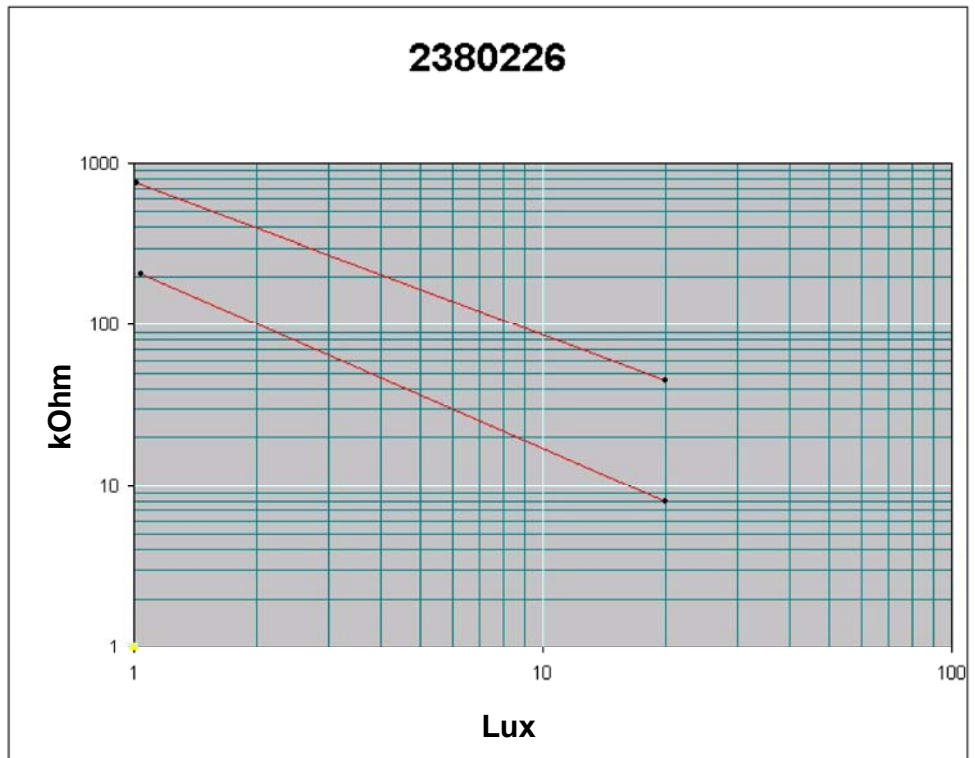

7136d04e/1102

Function

- Preconditions for startup
- Burner control is reset
 - All contacts in the line are closed
 - Only when firing on gas:
 - Air pressure switch «LP» is in its idle position
 - CPI contact is closed
 - No undervoltage
 - Heat demand contact is closed
 - Flame detector is darkened, no extraneous light

Undervoltage

| RMO88.53A1 RMG88.62A1 | RMO88.53A2 RMG88.62A2 | RMG/M88.62A2 |
|--|---|---|
| Safety shutdown from operating position in the event mains voltage drops below approx. AC 65 V | Safety shutdown from operating position in the event mains voltage drops below approx. AC 165 V | Safety shutdown from operating position in the event mains voltage drops below approx. AC 165 V |
| Repetition in the event mains voltage exceeds approx. AC 80 V | Repetition in the event mains voltage exceeds approx. AC 175 V | Repetition in the event mains voltage exceeds approx. AC 180 V |

Controlled intermittent operation

After no more than 24 hours of continuous operation, the burner control will automatically initiate a safety shutdown followed by an unshortened repetition of startup.

CPI

Only when firing on gas:

During the startup phase at the beginning of the waiting time «tw», the CPI (Closed Position Indicator) contact in the gas valve «BV1» is checked by the RMG88.62... / RMG/M88.62... to ensure it is closed. When the CPI contact subsequently opens, there is no response from the burner control during the times «t10 / t1 / t12». From program phase «B», that is, at the start of the safety time «TSA», the CPI contact is continuously checked to ensure it is open. If not, lockout will occur.

Oil preheater

Only when firing on oil:

When the oil is sufficiently preheated, contact «OW» in the external oil preheater closes. The closed position is monitored during the entire prepurge time «t1» (refer to illustration 7136d01, «Program sequence»).

Monitoring of time of oil preheater

If the oil preheater's release contact does not close after 600 seconds, lockout will be initiated.

Air damper control (only RMG/M88.62A2)

Checked air damper control to ensure ignition in the ignition load position. The predefined position must be reached on completion of the programmed closing time «t12» for the actuator. Otherwise, lockout will be initiated.

Detection of extraneous light

Only when firing on oil:

If extraneous light is detected, lockout will take place within the period of time «t3». Before a demand for heat is received (standby phase), only extraneous light is indicated by the red-green flash light in the lockout reset button. Extraneous light is indicated for a maximum of 25 seconds. If extraneous light is detected for a longer period of time, lockout will be initiated.

Only when firing on gas:

If extraneous light is detected, lockout will take place within the periods of time «t1» and «t12». During the times «t0» and «tw», only extraneous light is indicated by the red-green flash light in the lockout reset button. Extraneous light is indicated for a maximum of 25 seconds. If extraneous light is detected for a longer period of time, lockout will be initiated.

Flame supervision

When changing from the operating state to standby or repetition (only when firing on oil), a flame signal is permitted for a period of 10 seconds after the heat demand contact has opened. Otherwise, lockout will occur.

Loss of air pressure

Only when firing on gas:
 If air pressure switch «LP» changes to its idle position during the prepurge time «t1», the program will return to the beginning of «t10».
 Loss of air pressure during «t1» may occur no more than 4 times.
 If loss of air pressure occurs on completion of «t1», the burner control will immediately initiate lockout.

Fuse

If fuse is blown due to overload, the unit's life expectancy will be shortened.

Control sequence in the event of fault

If lockout occurs, the outputs for the fuel valves and ignition will immediately be deactivated (< 1 second).

| Cause | Response |
|--|--|
| General | |
| Mains failure | Repetition with unshortened program sequence |
| Voltage has dropped below the undervoltage threshold | Repetition with unshortened program sequence |
| Burner does not ignite after «TSA» | Lockout |
| Afterburn time > 10 seconds | Lockout |
| Only when firing on oil | |
| Loss of flame during operation | Maximum 3 repetitions, followed by lockout |
| Oil preheater's release contact does not close | Lockout 600 seconds after demand for heat |
| Oil preheater's release contact opens and closes more than 5 times during «t1» | Lockout |
| Extraneous light during «t0» and «tw» | Red-green signal lamp steady on, lockout after 25 seconds |
| Extraneous light during «t1» | Lockout |
| Only when firing on gas | |
| Loss of flame during operation | Immediate lockout |
| Contacts of air pressure switch «LP» have welded in their idle position | Lockout 10 seconds after the end of «t10» |
| «CPI» contact is open during «tw» | Lockout after approx. 20 s |
| Ignition load position not reached before start of «TSA» | Immediate lockout |
| Contacts of air pressure switch «LP» have welded in their working position | Prevention of startup and lockout after about 20 seconds |
| Loss of air pressure during «t1» | Maximum 4 repetitions at the start of «t10», followed by lockout |
| Loss of air pressure after the fuel valve has opened | Immediate lockout |
| Extraneous light during «t0» and «tw» | Red-green signal lamp flashes, lockout after 25 seconds |
| Extraneous light 5 seconds after completion of «tw» until start of «TSA» | Lockout |

Lockout

In the event of lockout, the burner control remains locked (lockout cannot be changed) and the red signal lamp will light up.
 This status is also maintained in the event of a mains failure.

Resetting the burner control

If lockout occurs, the burner control can immediately be reset. To do this, keep the lockout reset button depressed for about 1 second.

Operation, display, diagnosis

Operation

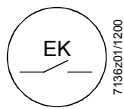

7138201/1200

Lockout reset button «EK...» is the key operating element for resetting the burner control and for activating / deactivating the diagnostic functions.

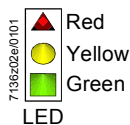

The multicolor LED is the key indicating element for both the visual diagnosis and the interface diagnosis.

Both «EK...» and LED are located under the transparent cover of the lockout reset button.

There are 2 diagnostic choices:

1. Visual diagnosis: Indication of operating state.
2. Interface diagnosis: With the help of the interface adapter OCI400 and PC software ACS400 or flue gas analyzers of different makes.

Visual diagnosis:

In normal operation, the different operating states are displayed in the form of color codes according to the color code table below. The interface diagnosis is activated by pressing the lockout reset button for at least 3 seconds (refer to Data Sheet 7614). If, by accident, the interface diagnosis has been activated, in which case the slightly red light of the signal lamp flickers, it can be deactivated by again pressing the lockout reset button for at least 3 seconds. The moment of switching over is indicated by a yellow light pulse.

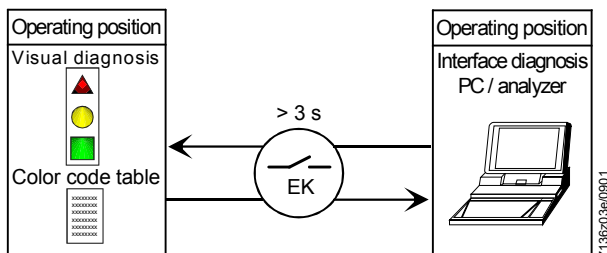

Indication of operating state

During startup, indication is according to the following table:

| Color code table | | |
|--|-----------------------|------------|
| Sequences used | Color code | Color |
| «tw», standby with permanent phase, waiting statuses | ○○○○○○○○○○○○ | Off |
| Oil: Oil preheater on Gas: Prepurging | ●..... | Yellow |
| Ignition phase, ignition controlled | ● ○ ● ○ ● ○ ● ○ ● ○ ● | Yellow-off |
| Operation, flame o.k. | □..... | Green |
| Operation, poor flame (when detector current drops below the recommended level for reliable operation) | □ ○ □ ○ □ ○ □ ○ □ ○ | Green-off |
| Undervoltage, built-in fuse | ● ▲ ● ▲ ● ▲ ● ▲ ● ▲ ● | Yellow-red |
| Fault, alarm | ▲..... | Red |
| Extraneous light | ▲ □ ▲ □ ▲ □ ▲ □ ▲ □ ▲ | Red-green |
| Error code output (e.g. 2 blinks) | ▲ ▲ ○ ▲ ▲ ○ ▲ ▲ ○ | Red-off |

Legend

- Steady on
 ● Yellow ○ Off
 ▲ Red □ Green

Diagnosis of cause of fault

After lockout, the red fault signal lamp remains steady on. In that condition, the visual diagnosis of the cause of fault according to the error code table can be activated by pressing the lockout reset button for more than 3 seconds. Pressing the reset button again for at least 3 seconds, the interface diagnosis will be activated. The interface diagnosis works only if the lockout reset button AGK20.43 extension is not fitted. For more detailed information, refer to Data Sheet 7614.

The following sequence activates the diagnosis of the cause of fault:

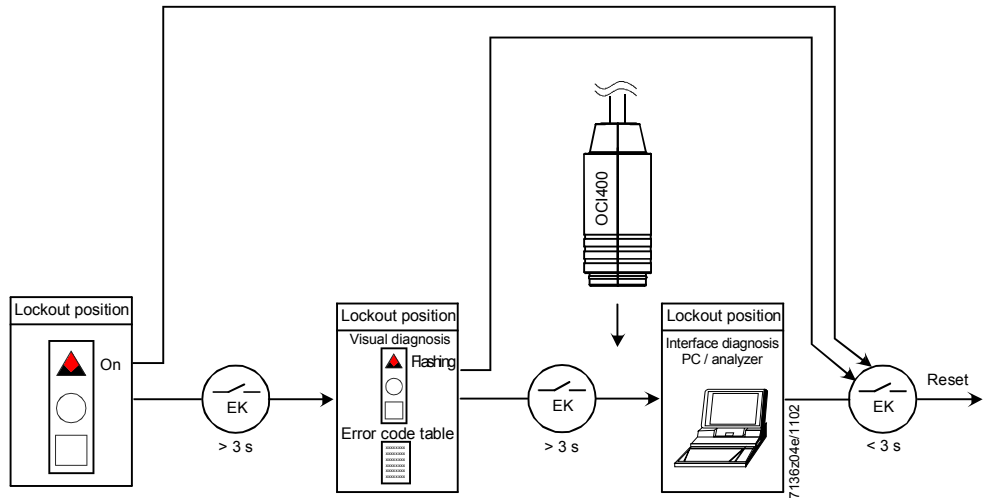

| Error code table | | | |
|------------------|------------------------------|------------------------------------|---|
| Oil | Gas | Blink code | Possible cause |
| RMO88.53... | RMG88.62... RMG/M88.62... | | |
| x | x | 2 x blinks • • | No establishment of flame at the end of «TSA» - Faulty or soiled fuel valves - Faulty or soiled flame detector - Poor adjustment of burner, no fuel - Faulty ignition |
| --- | x | 3 x blinks • • • | Faulty air pressure switch |
| x | x | 4 x blinks • • • • | Extraneous light |
| x | x | 5 x blinks • • • • • | «CPI» contact is open during «tw» |
| --- | x | 6 x blinks • • • • • • | - Faulty actuator - Actuator position not reached - Cams incorrectly adjusted |
| x | x | 7 x blinks • • • • • • • | Loss of flame during operation - Faulty or soiled fuel valves - Faulty or soiled flame detector - Poor adjustment of burner |
| x | --- | 8 x blinks • • • • • • • • | Monitoring of oil preheater time |
| x | x | 9 x blinks • • • • • • • • • | Free |
| x | x | 10 x blinks • • • • • • • • • • | Wiring error or internal error, output contacts; faults that cannot be detected, such as simultaneous faults |

During the time the cause of fault is diagnosed, the control outputs are deactivated.

- Burner remains shut down
- External fault indication remains deactivated
- Fault signal «AL» is activated

The fault diagnosis is quit and the burner switched on again by resetting the burner control. To do this, press the lockout reset button for about 1 second.

Connection diagrams and internal diagrams

RMO88.53A1

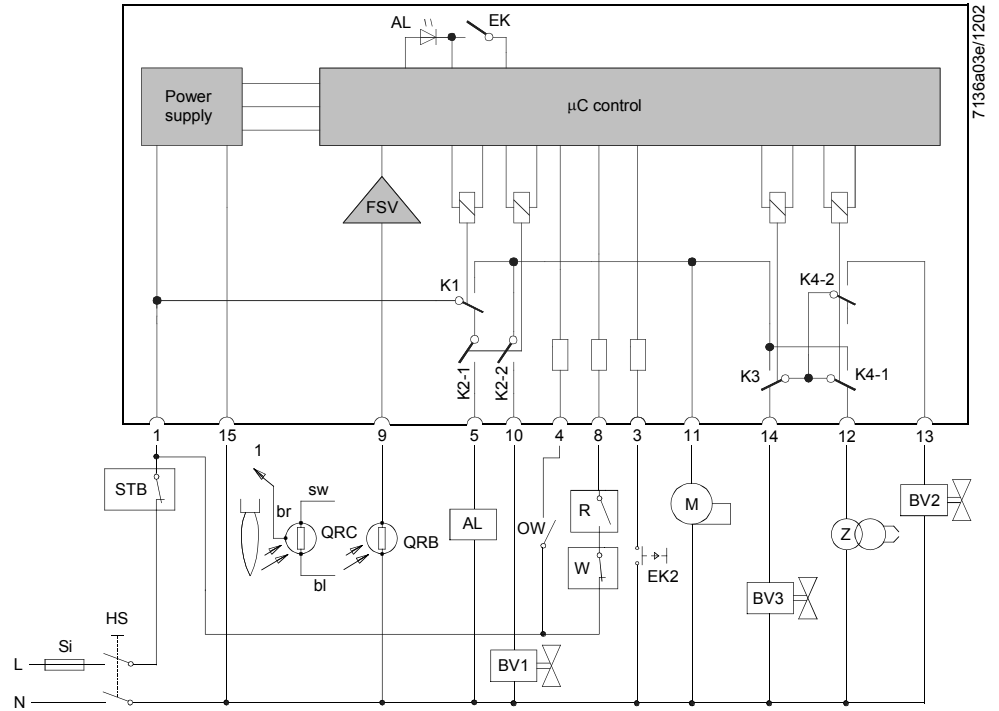

7136a03e/1202

RMO88.53A2

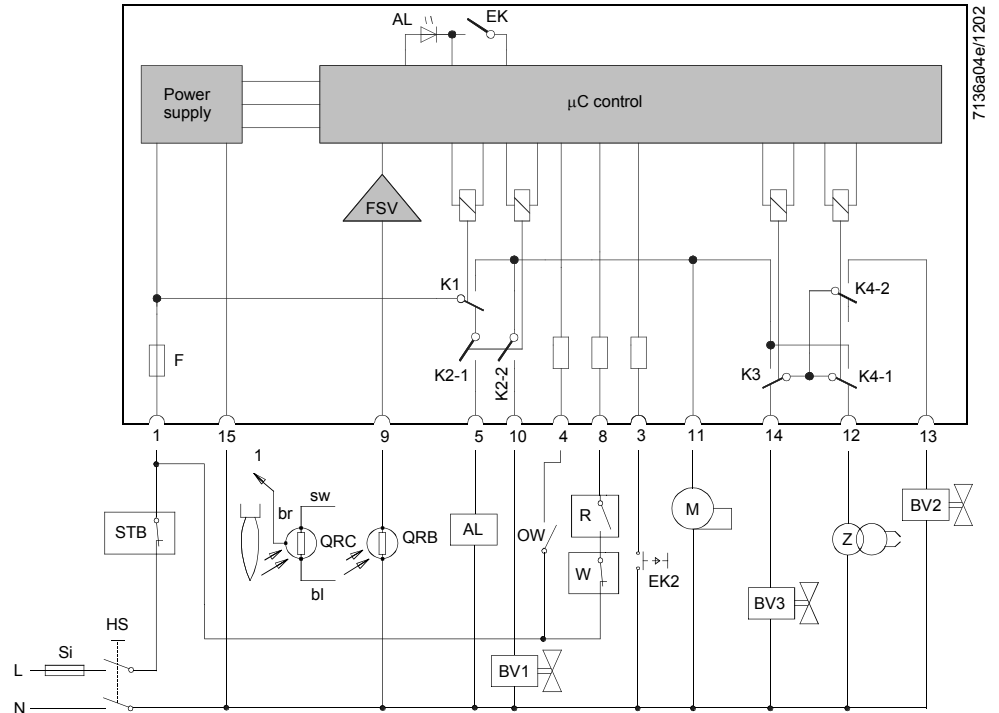

7136a04e/1202

Connection diagrams and internal diagrams (cont'd)

RMG88.62A1

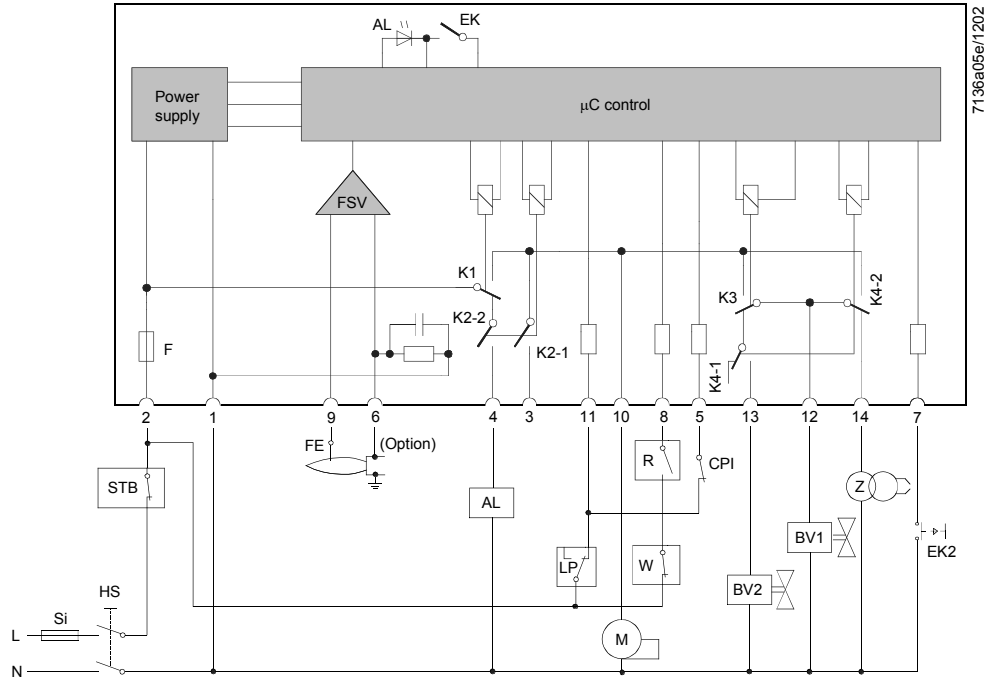

RMG88.62A2

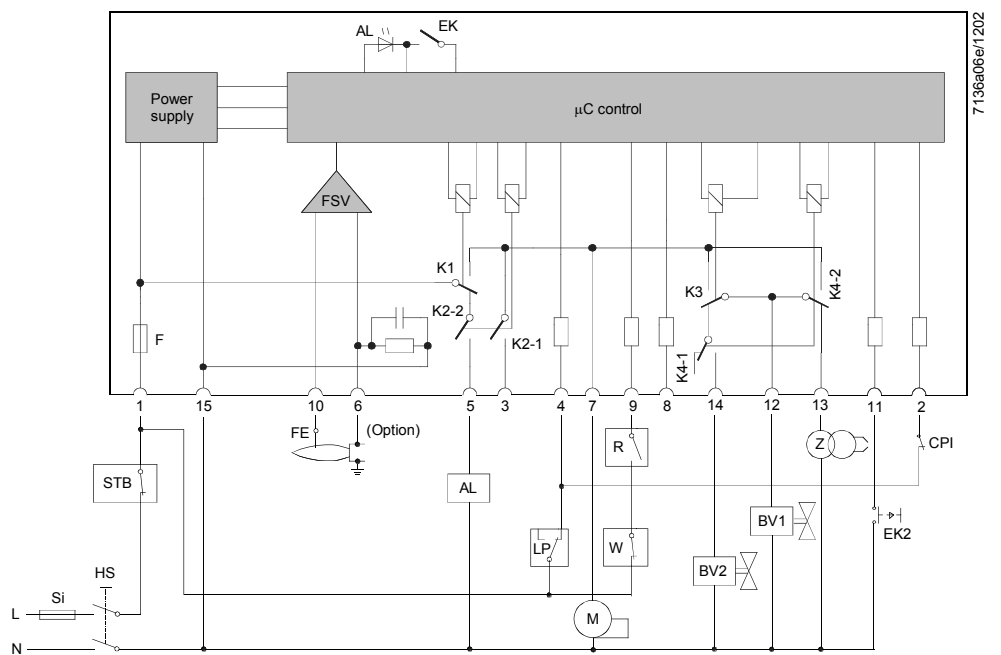

Connection diagrams and internal diagrams (cont'd)

RMG/M88.62A2

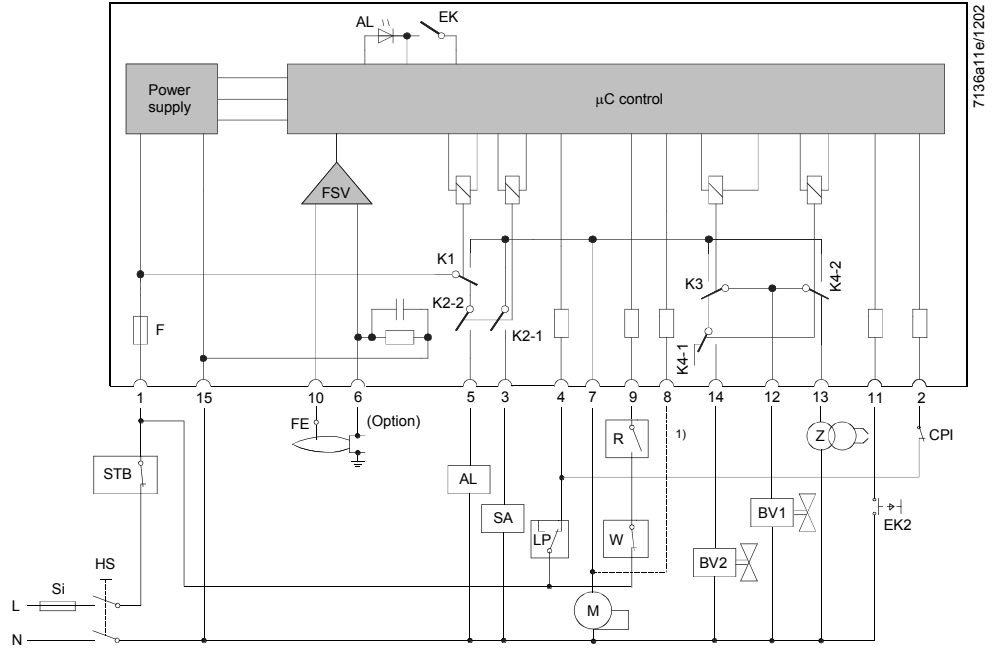

Legend

- | | | | |
|-------|-----------------------------|----------|-------------------------------------|
| AL | Alarm device | QRB1B... | Photoresistive detector |
| BV... | Fuel valve | QRC... | Blue-flame detector |
| CPI | Closed Position Indicator | bl | Blue |
| EK | Lockout reset button | br | Brown |
| EK2 | Remote lockout reset button | sw | Black |
| F | Built-in fuse | R | Control thermostat or pressurestat |
| FE | Ionization probe | SA | Actuator |
| FSV | Flame signal amplifier | Si | External primary fuse |
| HS | Main switch | STB | Safety limit thermostat |
| K... | Contacts of control relay | OW | Release contact of oil preheater |
| LP | Air pressure switch | W | Limit thermostat or pressure switch |
| M | Burner motor | Z | Ignition transformer |
- 1) If the actuator receives no feedback signal from the ignition load position, a wire link must be fitted across terminals 7 and 8

Connection diagrams and internal diagrams (cont'd)

RMG/M88.62A2 with actuator

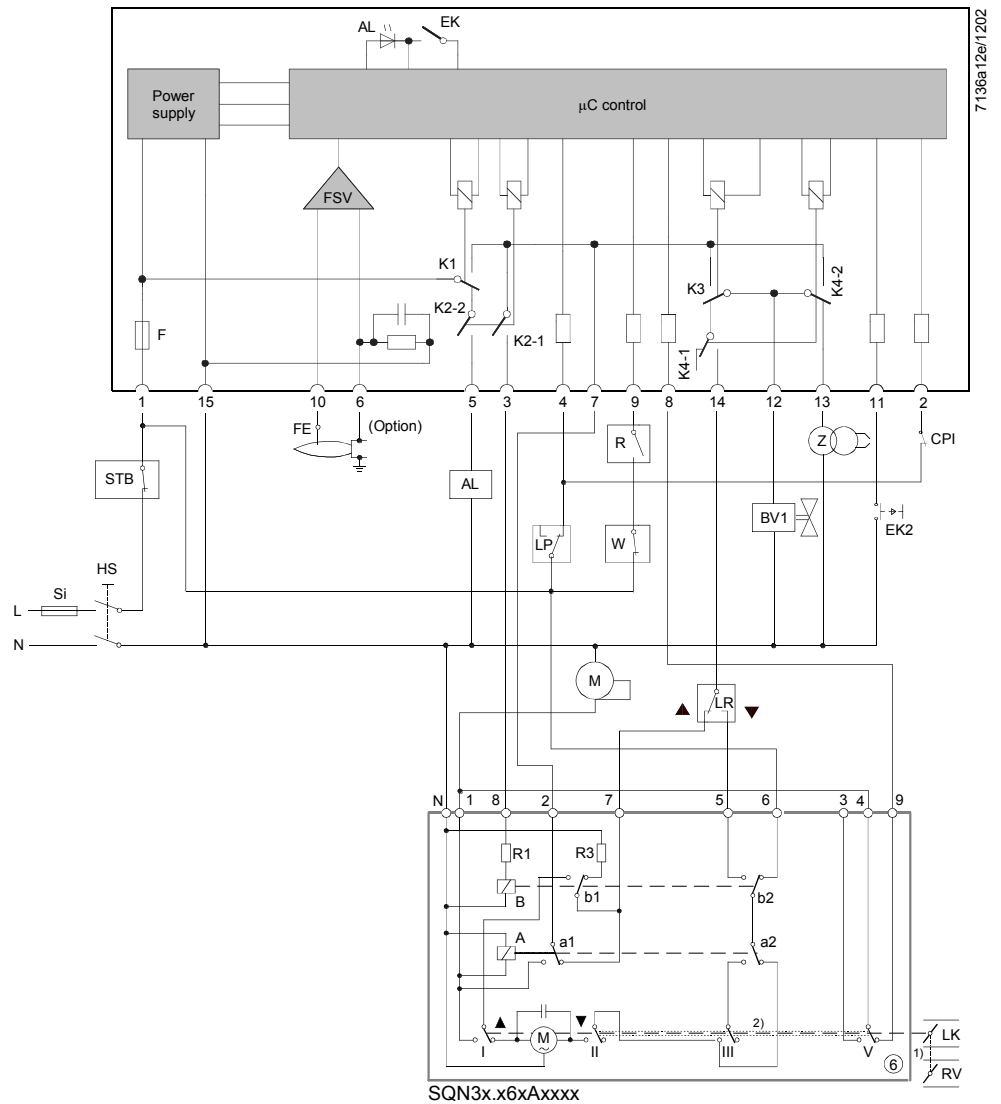

If the contacts of switch V welded in position 4 → 9, supervision of the ignition load position would be negated and would not be detected in operation. This means that the circuit welding only used for supervision purposes. The user must ensure that, in the event of failure (should the burner ignite at nominal load «NL»), no damage will occur.

Control sequence

RMO88.53A1
RMO88.53A2

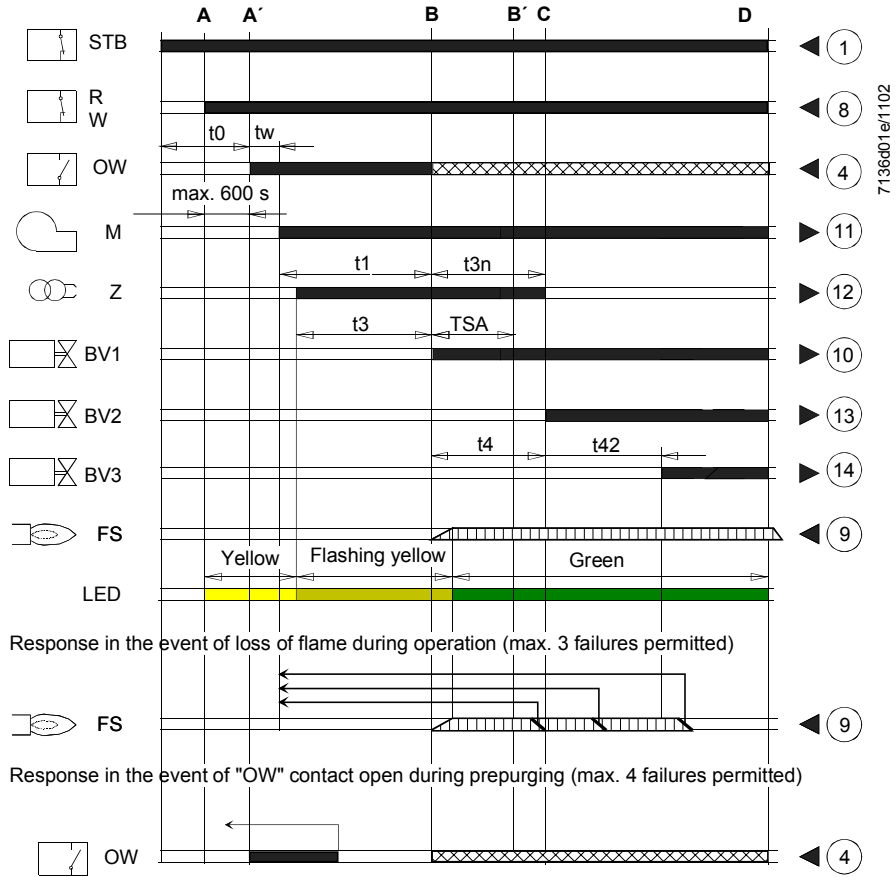

RMG88.62A1

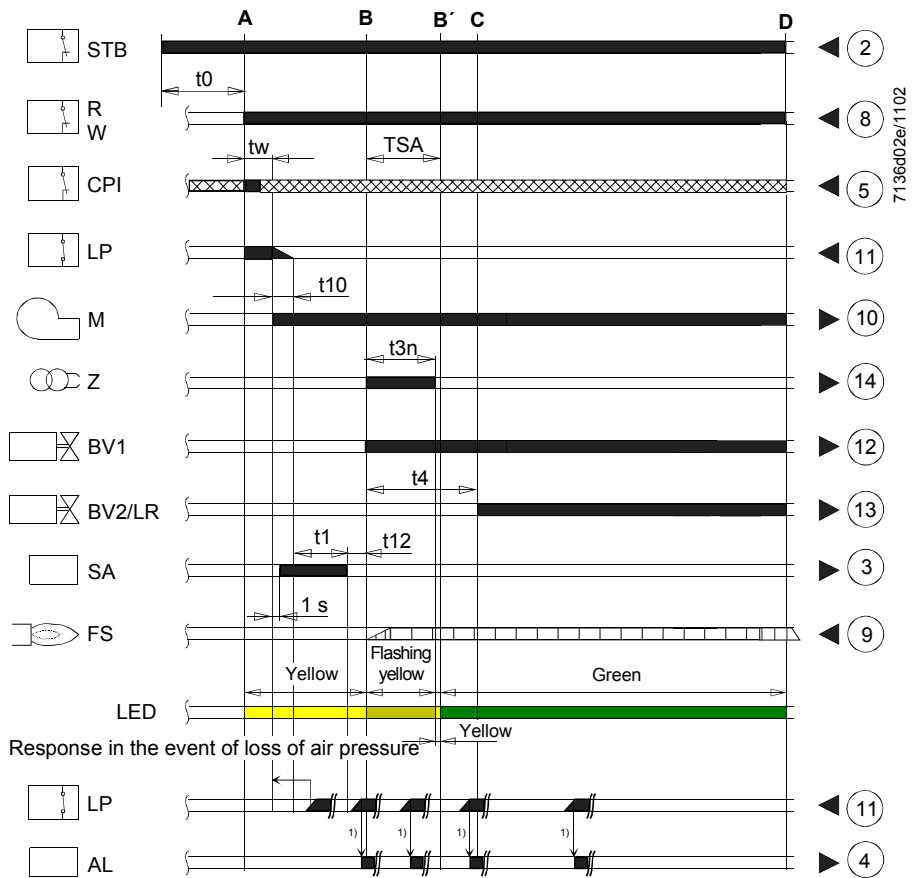

Control sequence (cont'd)

RMG88.62A2

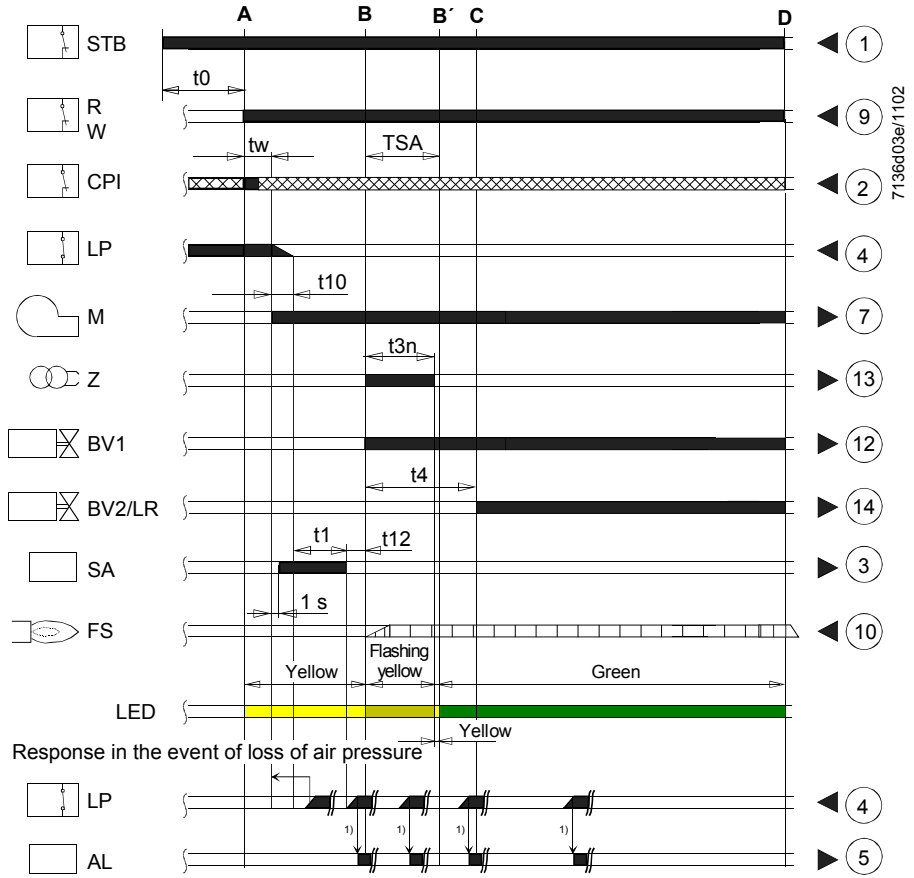

Control sequence (cont'd)

RMG/M88.62A2

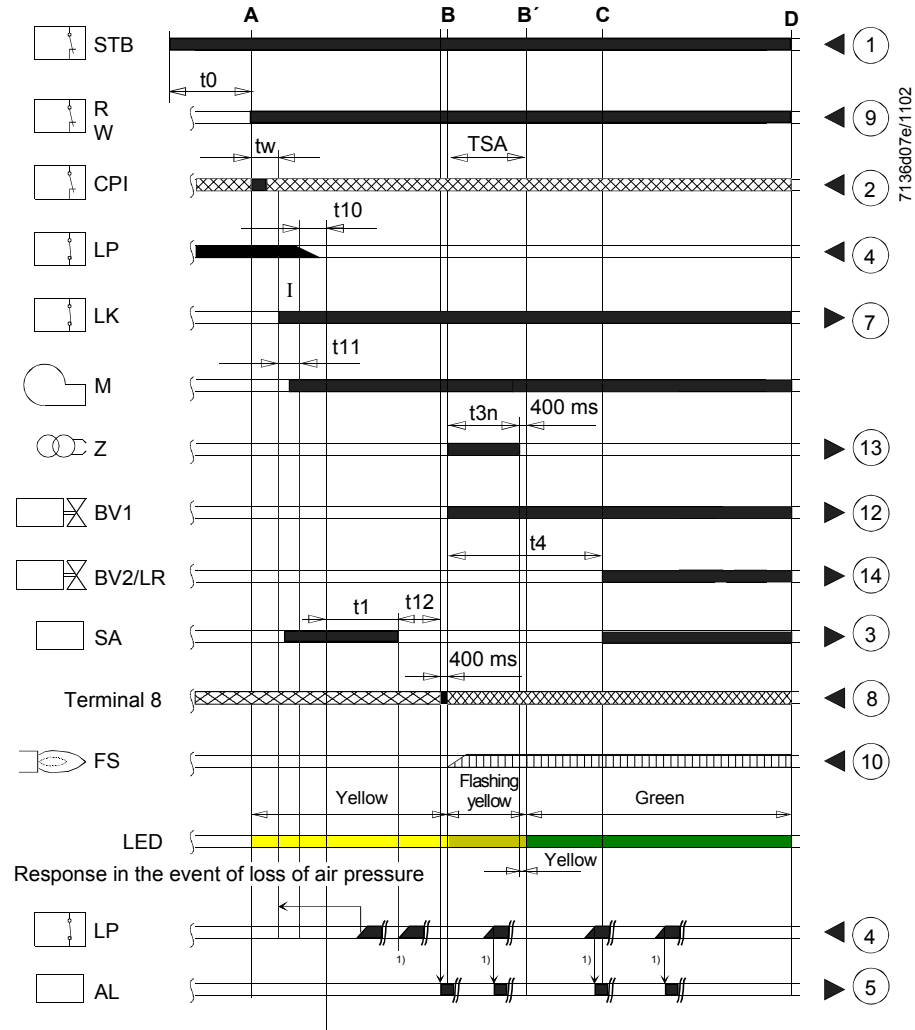

Legend

| | | | |
|-------|--|------|---|
| | Control signals of burner control | 1) | Lockout |
| | Required input signals | | |
| | Permitted input signals | | |
| A' | Beginning of startup with burners using «OW» | B-B' | «TSA» |
| A | Heat demand | C | Change to operation |
| B | End of prepurging, start of «TSA» | C-D | Operation |
| | | D | Change to standby |
| BV... | Fuel valve | R | Control thermostat or pressurestat |
| CPI | Closed Position Indicator | SA | Actuator |
| FS | Flame signal | STB | Safety limit thermostat |
| LP | Air pressure switch | OW | Release contact of oil preheater |
| LR | Load controller | W | Limit thermostat or pressure switch |
| M | Burner motor | Z | Ignition transformer |
| tw | Waiting time | t4 | Interval «BV1-BV2» |
| TSA | Ignition safety time | t10 | Specified time for air pressure signal |
| t0 | Waiting for heat demand from «R» | t11 | Programmed opening time for actuator «SA» |
| t1 | Prepurge time | t12 | Programmed closing time for actuator «SA» |
| t3n | Postignition time (ignition time during «TSA») | t42 | Interval «BV2-BV3» |

Dimensions

Dimensions in mm

Burner control with
plug-in base

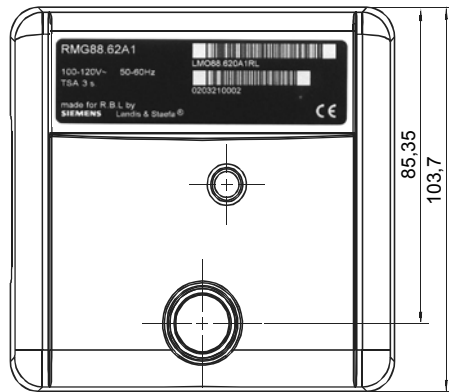
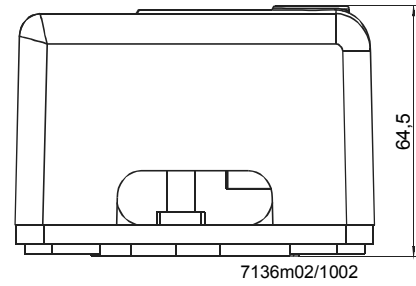
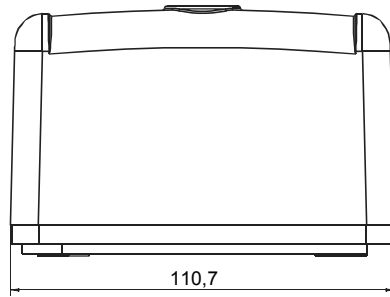

Burner control complete
with lockout reset but-
ton extension
AGK20.43 and plug-in
base

